

BLUE MOON

PRODUCT CATALOG

 IOWA ROTOCAST PLASTICS



**MOLSON
COORS** beverage
company

INDEX

RotoTough		4
Fabrication		16
Precision Series		28
Grab N' Go		35
Racks & Stackers		38
Breezers		44
Grizzly		46



HISTORY OF IRP

- 1985** Super Cooler (the predecessor to IRP) begins production of the original keg cooler in a building constructed on the founder/CEO's home property.
- 1986** Company name changes and becomes incorporated as Iowa Rotocast Plastics, Inc. and moves to new 4,000 sq ft location in Decorah, IA.
- 1994** The Arctic is born and sold to Coca-Cola. Kolor Graphics is created as an in-house printer to fulfill the growing demands.
- 1998** IRP moves to current location in Decorah, IA and constructs 20,000 sq ft production facility.
- 2006** Several additions totaling over 100,000 additional sq ft – fabrication line developed to satisfy increasing demand for fabricated carts and kiosks. A third rotational molding oven is added to the second IRP location - a large capacity oven.
- 2009** IRP adds a 60,000 sq ft second physical location.
- 2012** Grizzly Coolers is launched as the re-branded image of roto-molded coolers manufactured by IRP taking a more B2C-focused position in the market.
- 2016** IRP adds a powder coating line to the second IRP location. A fourth rotational molding oven is added to the main IRP location - a high volume oven.
- 2017** IRP is awarded the US Bank Stadium bid in Minneapolis, MN, launching a series of stadium and venue books of business to follow.
- 2019** IRP introduces an ACM line of fabricated carts for more cost effective construction. IRP is also awarded Wrigley Field and Allianz Field stadium bids.
- 2020** In response to Covid-19, IRP developed a line of hand sanitizers to promote health and safety. Nashville Soccer and Cincinnati Soccer stadiums both award fabrication bids to IRP.
- TODAY** Launched re-branded e-commerce website and constructed new staging area in our fabrication facility. Company restructures to allow for the next generation of family members to take on executive leadership roles.



Iowa Rotocast Plastics, incorporated in 1986, is an established manufacturer and supplier of merchandising equipment for the food and beverage industry. IRP caters to beverage brands and food-service and hospitality groups, as well as working directly with stadiums, venues, and arenas to fulfill year-over-year needs.

The IRP family of brands is divided into three main product categories: RotoTough™ products that include ice-down merchandising solutions and case stackers; wire racks and electronic refrigeration; and IRP's fabricated food & beverage equipment built for on/off premise. IRP equipment meets or exceeds required industry regulations and is NSF and UL approved.

NEW

BACKPACK COOLER

FEATURES

- Lightweight design - 2.8 lbs empty
- Custom branding capability
- Water resistant integrated pocket
- Carabiner style clips
- Keeps beverages cold 24 hours

DIMENSIONS

- 14" L x 6" W x 18 3/4" H

CAPACITY

- 15 - 12oz cans
- 12 - 12oz slim cans
- 10 - 16oz cans
- 6 - 24/25oz cans
- 10 - 20oz bottles
- 2.8 gallons



INTERIOR



TOP POCKET

LARGE ZIPPER HANDLE

BRANDING AREA

ADJUSTABLE STRAPS

CARABINER CLIPS



||

ROTOTOUGH

DURABLE ICE-DOWN MERCHANDISERS





ARCTIC



DIMENSIONS

51" W x 24" D x 38" H



FEATURES

- Interchangeable graphics
- Mold-in divider for easy brand separation
- Heavy duty wheels for easy mobility
- Mold-in handles and umbrella holder
- Optional locking lid to keep product safe



BUILD CAPACITY

- 448 - 12oz. cans
- 336 - 16oz. cans
- 196 - 20oz. bottles
- 196 - 24/25oz. cans
- 288 - quarts



Optional Pole Topper



SUPER ARCTIC



DIMENSIONS

60.5" W x 31.5" D x 38" H



FEATURES

- Interchangeable graphics
- Mold-in divider for easy brand separation
- Heavy duty wheels for easy mobility
- Mold-in handles and umbrella holder
- Optional locking lid to keep product safe



BUILD CAPACITY

- 720 - 12oz. cans
- 560 - 16oz. cans
- 384 - 20oz. bottles
- 324 - 24/25oz. cans
- 440 - quarts



**Optional Pole
Topper**

PUSH CART



DIMENSIONS

53.5" W x 30" D x 40" H



FEATURES

- Interchangeable graphics
- Optional cash register and umbrella for all-in-one mobile selling
- Built in handles for easy mobility
- Optional pole topper with graphics and LED light kit



BUILD CAPACITY

- 352 - 12oz. cans
- 261 - 16oz. cans
- 141 - 20oz. bottles
- 228 - quarts



TEXAS TANKER



DIMENSIONS

44.5" W x 27.25" D x 30.5" H



FEATURES

- RotoTough™ construction
- RotoTough™ divider for brand separation
- Heavy duty wheels
- Interchangeable graphic system



BUILD CAPACITY

- 8 - 12oz. cans
- 8 - 16oz. cans
- 7 - 20oz. bottles
- 7 - 24/25oz. cans
- 6 - quarts



SUPER COOLER



DIMENSIONS

24.5" D x 27" H



FEATURES

- RotoTough™ construction for extra durability
- Durable, insulated keg cooler
- Lid saves ice while allowing access to your tap



BUILD CAPACITY

- 1 keg



AVALANCHE



DIMENSIONS

30" W x 16" D x 35" H



FEATURES

- Interchangeable graphics
- Modular design for larger pack-out with smaller footprint
- Slide-in dividers for brand separation
- Recessed graphics to keep unit looking new
- Cross-merchandising options



BUILD CAPACITY

- 160 - 12oz. cans
- 112 - 16oz. cans
- 72 - 20oz. bottles
- 72 - 24/25oz. cans
- 112 - quarts



ICE CADDY



DIMENSIONS

36.25" W x 27" D x 35" H



FEATURES

- Interchangeable graphics
- Rototough™ construction & handles for easy moving
- Rototough™ removable lid for easy loading



BUILD CAPACITY

- 320 - 12oz. cans
- 240 - 16oz. cans
- 177 - 20oz. bottles
- 177 - 24/25oz. cans
- 232 - quarts



ICE CADDY 100



DIMENSIONS

22.25" W x 30.25" D x 28.75" H



FEATURES

- Interchangeable graphics
- Rototough™ construction
- Rototough™ sliding lid for easy
- *Custom graphics invalidate NSF certification.



BUILD CAPACITY

- 135 - 12oz. cans
- 100 - 16oz. cans
- 64 - 20oz. bottles
- 64 - 24/25oz. cans
- 84 - quarts
- 100 lbs. of ice





MERCH I



DIMENSIONS

21.25" Dia. x 36" H



FEATURES

- Interchangeable graphics
- Available in ice-less innovation: includes full set of ice packs that keeps product cold where ice is not an options
- Ice melt reservoir



BUILD CAPACITY

- 106 - 12oz. cans
- 82 - 16oz. cans
- 60 - 20oz. bottles
- 52 - 24/25oz. cans
- 72 - quarts

MERCH III



DIMENSIONS

37.25" H x 16.5" Dia.



FEATURES

- Interchangeable graphics
- Heavy duty wheel system for easy mobility
- Redesigned flat lid



BUILD CAPACITY

- 56 - 12oz. cans
- 42 - 16oz. cans
- 30 - 20oz. bottles
- 26 - 24/25oz. cans
- 44 - quarts

ICEBERG



DIMENSIONS

21.5" W x 16.5" D x 33.75" H



FEATURES

- Interchangeable graphics
- Unique design fits flat against aisle ends
- Heavy duty wheel system for easy mobility
- 5 quart internal reservoir



BUILD CAPACITY

- 88 - 12oz. cans
- 66 - 16oz. cans
- 46 - 20oz. bottles
- 42 - 24/25oz. cans
- 64 - quarts



ICE HAWK



DIMENSIONS

21.25" W x 36" D x 14.5" H"



FEATURES

- Crystal clear lid features a pin hinge system allowing visibility and complete access to product inside the merchandiser
- Improved, easy interchangeable graphics
- Premium casters for easy mobility



BUILD CAPACITY

- 106 - 12oz cans
- 82 - 16oz cans
- 60 - 20oz bottles
- 72 quarts



FROST BOX



DIMENSIONS

36" W x 24" D x 34.5" H"



FEATURES

- Interchangeable graphics
- Rototough™ construction
- Dividers to keep brands separate
- Available with skirting for high-end look



BUILD CAPACITY

- 144 - 12oz cans
- 105 - 16oz cans
- 105 - 20oz bottles
- 96 quarts



ICER ELITE



DIMENSIONS

17.25" Dia. x 9.75" H



FEATURES

- Great for back-bars or sampling
- Molded-in drain
- 360° branding



BUILD CAPACITY

- 28 - 12oz. cans
- 21 - 16oz. cans
- 19 - 20oz. bottles
- 18 - 24/25oz. cans
- 22 - quarts



MINI-MAXIMIZER



DIMENSIONS

11" W x 11" D x 7.5" H



FEATURES

- Multiple exterior areas to place graphics
- Light weight makes it easy to move to and from storage
- Small countertop footprint for virtually unlimited placement options



BUILD CAPACITY

- 9 - 12oz. cans
- 9 - 16oz. cans
- 6 - 20oz. bottles
- 6 - 24/25oz. cans
- 6 - quarts



MAXIMIZER



DIMENSIONS

16.75" W x 17.5" D x 12.25" H



FEATURES

- Large exterior area to place graphics
- Light weight makes it easy to move to and from storage
- Small countertop footprint for virtually unlimited placement options



BUILD CAPACITY

- 24 - 12oz. cans
- 20 - 16oz. cans
- 20 - 20oz. bottles
- 16 - 24/25oz. cans
- 24 - quarts

CHILLER



DIMENSIONS

36" W x 18" D x 8" H



FEATURES

- Large exterior area to place graphics
- Light weight makes it easy to move to and from storage
- Small countertop footprint for virtually unlimited placement options



BUILD CAPACITY

- 74 - 12oz. cans
- 74 - 16oz. cans
- 60 - 20oz. bottles
- 55 - 24/25oz. cans
- 48 - quarts



ICE ISLAND



DIMENSIONS

80" W x 35" D x 35" H



FEATURES

- Ice Island reservoir tank
- Optional header card and price strips
- Optional bridge rack available
- Full panel interchangeable graphics
- Shorter core with huge pack-out saves ice and money



BUILD CAPACITY

- 8 - 12oz. cans
- 8 - 16oz. cans
- 7 - 20oz. bottles
- 7 - 24/25oz. cans
- 6 - quarts





TEXAS ICER



DIMENSIONS

48" W x 24" D x 36" H



FEATURES

- Interchangeable graphics
- Large pack-out with shelf below
- Heavy-duty drain assembly with 16 quart capacity



BUILD CAPACITY

- 128 - 12oz. cans
- 112 - 16oz. cans
- 105 - 20oz. bottles
- 105 - 24/25oz. cans
- 120 - quarts

TEXAS ICER MINI



DIMENSIONS

23.5" W x 23.5" D x 32.5" H



FEATURES

- Interchangeable graphics
- Dividers for brand separation



BUILD CAPACITY

- 98 - 12oz. cans
- 63 - 16oz. cans
- 36 - 20oz. bottles
- 36 - 24/25oz. cans
- 64 - quarts

TEXAS ICER JR.



DIMENSIONS

36" W x 24" D x 34.25" H



FEATURES

- Interchangeable graphics
- Designed with convenient shelf below
- Dividers for brand separation



BUILD CAPACITY

- 96 - 12oz. cans
- 74 - 16oz. cans
- 74 - 20oz. bottles
- 74 - 24/25oz. cans
- 80 - quarts



RECYCLING CONTAINER



DIMENSIONS

21" W x 21" D x 41.239" H w/lid



FEATURES

- 2 graphic areas on each side
- Choice of circle or rectangular holes
- Rounded top prevents resting objects
- 80% recycled material construction available



BUILD CAPACITY

- 40-45 Gallon bag



RECYCLE BIN I



DIMENSIONS

22" W x 22" D x 39" H w/lid



FEATURES

- Stackable design
- Pyramid lid ensures containers are not placed on top of unit
- 100% recycled material construction
- Perfect for stadiums, special events & stores



BUILD CAPACITY

- 60 Gallon bag



RECYCLE BIN CAN



DIMENSIONS

21" Dia x 35.75" H w/lid



FEATURES

- Interchangeable graphics
- 360° graphic area
- Circular hole suited for beverage containers
- Perfect for stadiums, special events and stores



BUILD CAPACITY

- 60 Gallon bag



HAWKER ELITE



DIMENSIONS

23.5" W x 23.5" D x 32.5" H



FEATURES

- New and improved padded harness with harness attachment featuring quick detach system
- Rotomolded construction features molded-in handles with nestable design for easy storage and is 100% recyclable
- Ergonomic curved back and lightweight - the lightest hawker on the market!
- Large Recessed graphic area to amplify your brand



BUILD CAPACITY

- 64 - 12oz. cans
- 45 - 16oz. cans
- 26 - 20oz. bottles
- 25 - 24/25oz. cans
- 40 - quarts



MULTI HAWKER ELITE



DIMENSIONS

23.125" W x 17.875" D x 7.375" H



BUILD CAPACITY

- 32 - 12oz. cans
- 32 - 16oz. cans
- 24 - 20oz. bottles
- 24 - 24/25oz. cans
- 20 - quarts



BLUE MOON

||

FABRICATION

PURPOSE BUILT CARTS & KIOSKS





Bucket Insert



ROTOMOLDED PUB TABLE NEW



DIMENSIONS

35" Dia x 41.875" H



FEATURES

- Cost effective Rotomolded base & top
- Table top graphics
- Optional bucket insert on table top (14.25" Dia)
- Available with branded graphics



DIMENSIONS

30 1/2" L x 74" W x 45 3/8" H



FEATURES

- 2 - 58qt Consumable ice bins w/ SS lids - NSF Approved
- 2 - 14" Speed Rails
- 15 gallon Water Reservoir tank
- 4" Casters
- Bumper & Skirting
- Available in Black or Brushed ACM
- Branding availability on front & sides

ELECTRIC OPTION

- 20A POS Receptacle
- Undercounter LED lights customer & server sides



Umbrella Mount



PACKAGE TRIKE **NEW**



DIMENSIONS

88" L x 26" W x 45.5" H



FEATURES

- Dual sided stainless steel lid
- 100 qt drop in
- Locking storage underneath
- Metal trike frame
- Interchangeable graphics



BUILD CAPACITY

- 147 - 12 oz slim cans
- 120 - 12 oz cans
- 90 - 16 oz cans
- 70 - 24/25 oz cans
- 70 - 20 oz bottles

DRAFT TRIKE **NEW**



DIMENSIONS

88" L x 26" W x 56.5" H



FEATURES

- Double spigot draft tower
- Iced-down coil bin w/lid
- 14" Drip tray
- 11 Gallon reservoir tank
- Interchangeable graphics



BUILD CAPACITY

- 2 - 1/6 barrel kegs



BAR CART IPC-280



DIMENSIONS

53.5" W x 26" D x 39.5" H



FEATURES

- RotoTough™ product shelf
- RotoTough™ divider for brand separation
- RotoTough™ sliding locking lid
- Available with canopy
- Interchangeable graphic system



BUILD CAPACITY

- 448 - 12oz. cans
- 336 - 16oz. cans
- 196 - 20oz. bottles
- 196 - 24/25oz. cans
- 280 - quarts



IPC-280



DIMENSIONS

53.5" W x 26" D x 96" H



FEATURES

- RotoTough™ product shelf
- RotoTough™ divider for brand separation
- RotoTough™ sliding locking lid
- Available with canopy
- Interchangeable graphic system



BUILD CAPACITY

- 448 - 12oz. cans
- 336 - 16oz. cans
- 196 - 20oz. bottles
- 196 - 24/25oz. cans
- 280 - quarts



CYK



DIMENSIONS

60.5" W x 31" D x 96" H



FEATURES

- RotoTough™ illuminated canopy
- RotoTough™ serving shelf
- RotoTough™ divider for brand separation
- RotoTough™ handles for easy moving
- Interchangeable graphic system



BUILD CAPACITY

- 420 - 12oz. cans
- 296 - 16oz. cans
- 204 - 20oz. bottles
- 176 - 24/25oz. cans
- 240 - quarts



MFC-K89 PACKAGE



DIMENSIONS

89" W x 31" D x 91.5" H



FEATURES

- ACM canopy and brushed stainless steel sides
- Down lighting
- Stainless steel serving shelf and theft guard
- Rubber skirting & heavy duty bumper to help protect unit
- Heavy duty casters for easy mobility



BUILD CAPACITY

- 380 - 12oz. cans
- 300 - 16oz. cans
- 180 - 24/25oz. cans
- 270 - quarts



MFC-K89 DRAFT



DIMENSIONS

84" W x 25" D x 91.5" H



FEATURES

- ACM canopy and brushed stainless steel sides
- Down lighting
- Stainless steel serving shelf and theft guard
- Rubber skirting & heavy duty bumper to help protect unit
- Heavy duty casters for easy mobility



BUILD CAPACITY

- Up to 4 half keg barrels



ICC-1



DIMENSIONS

60" W x 30" D x 98" H



FEATURES

- Industry exclusive telescoping canopy
- Product shelf with plexi front to provide theft elimination and a cleaner serving area.
- Interchangeable graphics system
- Rotomolded construction & heavy duty wheels
- Molded-in divider for brand separation



BUILD CAPACITY

- 598 - 12oz. cans
- 428 - 16oz. cans
- 240 - 24/25oz. cans
- 320 - quarts

4-KEG DRAFT ELITE



DIMENSIONS

84" W x 25" D x 108" H



FEATURES

- New illuminated canopy with down lighting
- Full panel Interchangeable graphics
- Steel frame for optimal strength
- 6" heavy duty casters
- Stainless steel uprights



BUILD CAPACITY

- Up to 4 half keg barrels

PACKAGE ELITE



DIMENSIONS

62" W x 32" D x 91" H



FEATURES

- New illuminated canopy with down lighting
- Full panel Interchangeable graphics
- Steel frame for optimal strength
- 6" heavy duty casters
- Stainless steel uprights



BUILD CAPACITY

- 612 - 12oz. cans
- 432 - 16oz. cans
- 292 - 20oz. bottles
- 280 - 24/25oz. cans
- 344 - quarts

THE UNIVERSAL



3 PIECE UNIVERSAL DRAFT



THE UNIVERSAL

SELECT FROM GREAT FEATURES

If you can dream it, you can build it with the IRP Universal Ultimate Selling Station. Mix and match any option and create any size of selling station needed for your location, on or off premise. Customizing your Universal System is a quick and easy way to get the most use from your chosen unit. Our large optional canopy provides excellent shade for vendors, as well as shelter from the elements. Both large and small support carts provide extra storage and surface area. Locking lids keep your merchandise safe and secure. If you can dream it, we can create it. Customize your Universal today!

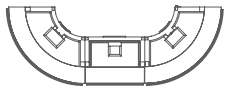

3 PIECE

10' 7.875" W x 3' 9.875" D x 7' 6.5" H

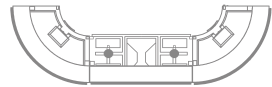

3 PIECE DRAFT

14' 7" W x 4' D x 7' 7" H

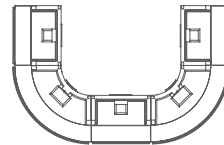

5 PIECE

10' 8" W x 6' 10" D x 7' 6.5" H

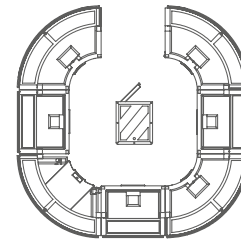

7 PIECE

10' 8" W x 10' 8" D x 7' 6.5" H

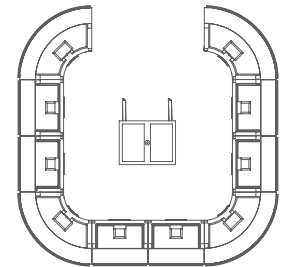

10 PIECE

13' 8" W x 13' 8" D x 7' 6.5" H



CURVE



DIMENSIONS

66" W x 33" D x 91" H



FEATURES

- RotoTough™ construction
- Optional external reservoir and locking lids



BUILD CAPACITY

- 452 - 12oz. cans
- 374 - 16oz. cans
- 240 - 20oz. bottles
- 212 - 24/25oz. cans
- 280 - quarts



STRAIGHT



DIMENSIONS

36" W x 28" D x 91" H



FEATURES

- RotoTough™ construction
- Optional external reservoir and locking lids



BUILD CAPACITY

- 336 - 12oz. cans
- 264 - 16oz. cans
- 170 - 20oz. bottles
- 156 - 24/25oz. cans
- 200 - quarts



UNIVERSAL DRAFT



DIMENSIONS

84" W x 24.75" D x 87" H



FEATURES

- One 4 keg draft refrigerator w/ draft equipment
- Full panel base graphics
- Full panel, back-lit header graphics
- Header upright graphics
- 6" TPR casters



BUILD CAPACITY

- Up to four kegs



A-FRAME CART



DIMENSIONS

84" W x 25" D x 108" H



FEATURES

- 6" HD casters
- Stainless steel uprights with sneeze guard and serving shelf
- Bumper and skirt for high end look and protection



BUILD CAPACITY

- Up to 4 kegs



BILLBOARD ARCTIC



DIMENSIONS

77" W x 35.5" D x 91.25" H



FEATURES

- LED down lighting
- Elevated serving shelf and stainless steel counter tops
- Arctic body with casters and locking lid
- Steel frame with ACM exterior
- Large frontal graphic area



BUILD CAPACITY

- 448 - 12oz. cans
- 336 - 16oz. cans
- 196 - 20oz. bottles
- 196 - 24/25oz. cans
- 288 - quarts



REFRACTING ELITE



DIMENSIONS

62" W x 32.5" D x 91" H



FEATURES

- Industry exclusive illuminated canopy with down lighting
- Full panel Interchangeable graphics
- Bumper and skirt for high end look and protection



BUILD CAPACITY

- 612 - 12oz. cans
- 432 - 16oz. cans
- 292 - 20oz. bottles
- 280 - 24/25oz. cans
- 344 - quarts



REFRACTING COMBO



DIMENSIONS

116.75" W x 34.75" D x 97.25" H



FEATURES

- Refrigerated single keg draft unit
- Drop in ice well for packaged product



BUILD CAPACITY

- 186 - 12oz. cans
- 120 - 16oz. cans
- 122 - 16oz. bottles
- 104 - 20oz. bottles

LEINENKUGEL KIOSK



DIMENSIONS

180" W x 120.75" D x 99.25" H



FEATURES

- Undercounter refrigerator
- Pull out sink
- Direct draw 4 keg cooler
- Lighted display - glastender



BLUE MOON KIOSK



DIMENSIONS

180" W x 120" D x 100" H



FEATURES

- Undercounter refrigerator
- Pull out sink
- Direct draw 4 keg cooler
- Lighted display - glastender





PRECISION SERIES
PACKAGE & DRAUGHT

||



*Regional brands available by market plan



PRECISION SERIES BOX DRAUGHT

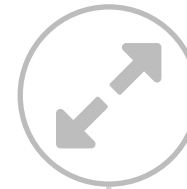

DIMENSIONS
96" L x 25" D x 95" H



CAPACITY
• 4 - half keg barrels



BREEZER UR-2 CAPACITY

- 630 - 12oz cans
- 630 - 16oz cans
- 480 - 24oz cans



*Regional brands available by market plan



PRECISION SERIES BOX PACKAGE

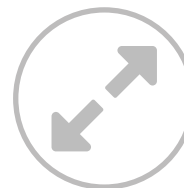

DIMENSIONS
92" L x 32" D x 91" H



CAPACITY

- 380 - 12oz cans
- 300 - 16oz cans
- 180 - 24oz cans



BREEZER UR-2 CAPACITY

- 630 - 12oz cans
- 630 - 16oz cans
- 480 - 24oz cans



*Regional brands available by market plan



PRECISION SERIES 6" BOX DRAUGHT

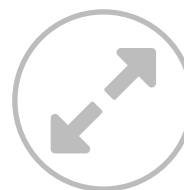

DIMENSIONS

96" L x 25" D x 95" H



CAPACITY

• 4 - half keg barrels



BREEZER UR-2 CAPACITY

- 630 - 12oz cans
- 630 - 16oz cans
- 480 - 24oz cans



*Regional brands available by market plan



PRECISION SERIES 6" BOX PACKAGE

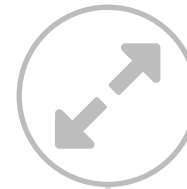

DIMENSIONS

92" L x 32" D x 91" H



CAPACITY

- 380 - 12oz cans
- 300 - 16oz cans
- 180 - 24oz cans



BREEZER UR-2 CAPACITY

- 630 - 12oz cans
- 630 - 16oz cans
- 480 - 24oz cans



*Regional brands available by market plan



PRECISION SERIES SPOILER DRAUGHT

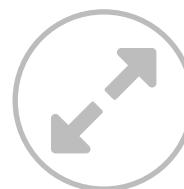

DIMENSIONS

96" L x 25" D x 95" H



CAPACITY

• 4 - half keg barrels



BREEZER UR-2 CAPACITY

- 630 - 12oz cans
- 630 - 16oz cans
- 480 - 24oz cans



*Regional brands available by market plan



PRECISION SERIES SPOILER PACKAGE

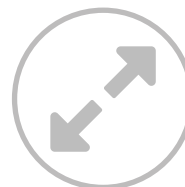

DIMENSIONS
92" L x 32" D x 91" H



CAPACITY

- 380 - 12oz cans
- 300 - 16oz cans
- 180 - 24oz cans



BREEZER UR-2 CAPACITY

- 630 - 12oz cans
- 630 - 16oz cans
- 480 - 24oz cans

||

GRAB N' GO SYSTEM

Miller
Lite

Miller
Lite

Miller
Lite

Miller
Lite

CELEBRATE RESPONSIBLYSM

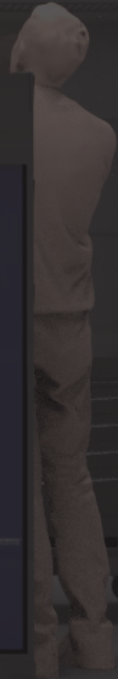



GRAB AND GO

CROWD CORRAL



DIMENSIONS
48" W x 16" D x 59.75" H



- FEATURES**
- Optional hanging chip rack
 - Interchangeable graphic area
 - Sturdy metal frame
 - Plastic LDPE feet for grip

G&G DOUBLE UR-2



DIMENSIONS
62.125" W x 32" D x 100.125" H



- FEATURES**
- Cyclopetane insulation
 - Heavy duty wire shelves
 - Electronic fan motors
 - LED perimeter lighting



- BUILD CAPACITY**
- 630 - 12oz cans
 - 630 - 16oz cans
 - 480 - 24oz cans

32" POS



DIMENSIONS
33.5" W x 34" D x 36.260" H



- FEATURES**
- Lockable storage area
 - Point of scale access port



GRAB AND GO

G&G UR-2



DIMENSIONS

62.125" W x 32" D x 100.125" H



FEATURES

- Cyclopentane insulation
- Heavy duty wire shelves
- Electronic fan motors
- LED perimeter lighting



BUILD CAPACITY

- 630 - 12oz cans
- 630 - 16oz cans
- 480 - 24oz cans

G&G DOUBLE UR-2



DIMENSIONS

118.125" W x 32" D x 100.125" H



FEATURES

- Cyclopentane insulation
- Electronic temperature control
- Heavy duty casters
- Durable steel construction



BUILD CAPACITY

- 1,260 - 12oz cans
- 1,260 - 16oz cans
- 960 - 24oz cans

32" POS



DIMENSIONS

33.5" W x 34" D x 36.260" H



FEATURES

- Lockable storage area
- Point of scale access port



RACKS & STACKERS

BRAND MERCHANDISERS





SS INTERCHANGEABLE RACK



DIMENSIONS

24.5" W x 17" D x 46.5" H



FEATURES

- Interchangeable graphics
- Four shelves with shelf strip areas
- Heavy duty casters for easy mobility



BUILD CAPACITY

- 32 - 6 pack bottles
- 24 - 12 pack cans
- 12 - 18 pack cans
- 8 - 30 pack cans



SS MINI RACK



DIMENSIONS

20" W x 11" D x 62" H



FEATURES

- Interchangeable graphics
- Four shelves with shelf strip areas



BUILD CAPACITY

- 16 - 6 pack bottles
- 12 - 12 pack cans
- 4 - 18 pa cans
- 4 - 30 pack cans



SS WEEKENDER SMALL



DIMENSIONS

32" W x 17" D x 61.5" H



FEATURES

- Interchangeable graphics
- Heavy duty system for large pack-out display
- Stainless steel construction
- Four casters for easy mobility



BUILD CAPACITY

- 24 - 12 pack cans
- 12 - 24 packs



SS WEEKENDER LARGE



DIMENSIONS

32" W x 34.5" D x 61.5" H



FEATURES

- Interchangeable graphics
- Heavy duty system for large pack-out display
- Stainless steel construction
- Four casters for easy mobility



BUILD CAPACITY

- 72 - 12 pack cans
- 36 - 24 packs



5 SHELF RACK NEW



DIMENSIONS

16" W x 16" D x 74.5" H
Shelf: 9.25" x 14.5"



FEATURES

- Interchangeable graphics
- Five shelves with price strip areas
- Product accessible from both sides
- Small Footprint - Big Pack out



BUILD CAPACITY

- 75 - 12oz cans
- 75 - 16oz cans
- 30 - 4 pack slim cans
- 15 - 8 pack slim cans
- 10 - 6 pack bottles



MAXIM RACK



DIMENSIONS

36" W x 17" D x 72" H



FEATURES

- Interchangeable graphics
- Top wire rack for snacks or smaller items
- Sturdy wire shelves for large cases
- Easy roll casters



BUILD CAPACITY

- Top Shelf: 35" x 12"
- Bottom Shelf: 36" x 17"



ROLLING RACK XL NEW



DIMENSIONS

46.625" W x 10.125" D x 20.875" H



FEATURES

- Interchangeable graphics
- 2 shelves for stacking product
- Steel construction
- Four casters for easy mobility



BUILD CAPACITY

- 36 - 12 pack cans
- 18 - 24 pack cans

LOW RIDER NEW



DIMENSIONS

46.5" W x 10.5" D x 10.5" H



FEATURES

- Interchangeable graphics
- Heavy duty casters for easy mobility
- Available with or without casters



BUILD CAPACITY

- 30 - 12 pack cans
- 15 - 24 pack cans



CASE-STACKER I



DIMENSIONS

16.5" W x 11.5" D x 4.5" H



BUILD CAPACITY

- 12oz. 12 pk glass bottles - 6 pks, 2 per layer
- 12oz. fridge pk - 8 packs, 2 per layer
- 12oz. 12 pk - 10 pks, 2 per layer
- 12oz. 24 pk - 5 pks, 1 per layer
- 12oz. 30 pk - 6 pks, 2 per layer
- 16oz. 18 pk - 5 pks, 1 per layer
- Aluminum bottles 9 pk - 6 pks, 2 per layer

CASE-STACKER II



DIMENSIONS

20.5" W x 16.5" D x 4.5" H



BUILD CAPACITY

- 12oz. 12 pk glass bottles - 12 pks, 4 per layer
- 12oz. fridge pk - 24 pks, 4 per layer
- 12oz. 12 pk - 20 pks, 4 per layer
- 12oz. 24 pk - 10 pks, 2 per layer
- 12oz. 30 pk - 6 pks, 2 per layer
- 16oz. 18 pk - 8 pks, 2 per layer
- Aluminum bottles 9 pk - 12 pks, 4 per layer

CASE-STACKER III



DIMENSIONS

32" W x 16" D x 4.5" H



BUILD CAPACITY

- 12oz. 12 pk glass bottles - 18 pks, 6 per layer
- 12oz. fridge pk - 30 pks, 6 per layer
- 12oz. 12 pk - 30 pks, 6 per layer
- 12oz. 24 pk - 15 pks, 3 per layer
- 12oz. 30 pk - 12 pks, 4 per layer
- 16oz. 18 pk - 16 pks, 4 per layer
- Aluminum bottles 9 pk - 24 pks, 8 per layer

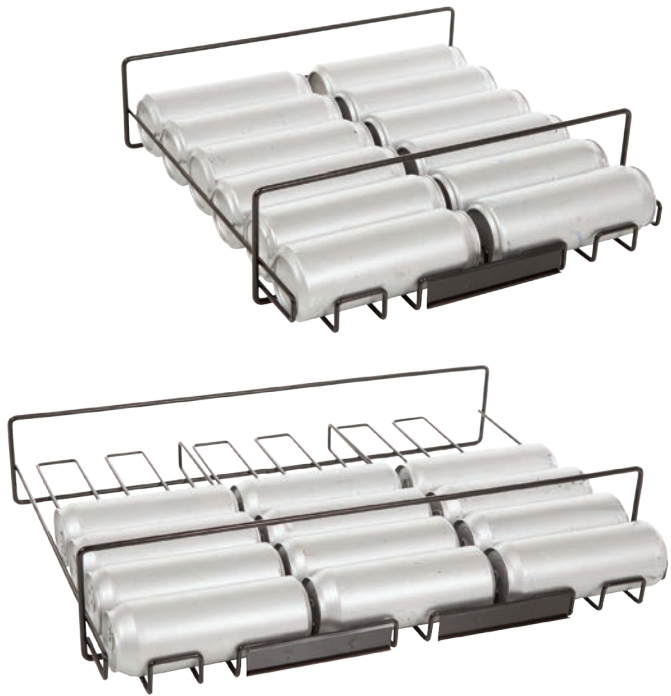

UNDERSHELF RACK



FEATURES

- Steel and wire rack
- Undershelf made from 1/4" & 3/16" B.B. 1008 wire and sheet metal.



DIMENSIONS

2 WIDE

20.25" W x 21.5" D
x 4.5" H

3 WIDE

25.25" W x 21.75" D
x 4.5" H



BUILD CAPACITY

- 14 - 16oz. cans
- 21 - 16oz. cans



HANGING 6-PACK RACK



DIMENSIONS

24.5" W x 7.5" D x 65.5" H



FEATURES

- Use in displays or on cooler doors
- Six shelves of product display
- Adjustable width bracket



BUILD CAPACITY

- 18 - 6 packs



HANGING 24oz. CAN RACK



DIMENSIONS

24.625" W x 5" D x 65.75" H



FEATURES

- Use in displays or on cooler doors
- Seven shelves of product display
- Adjustable width bracket



BUILD CAPACITY

- 56 - 24/25oz. cans



SIDE KICK RACK



DIMENSIONS

9" W x 5" D x 52" H



FEATURES

- Steel and wire rack
- For use along side the Hanging 6-Pack Rack or Hanging 24oz. Can Rack



BUILD CAPACITY

- 6 - 6 pack bottles



BIG CAN RACK



DIMENSIONS

3.5" W x 3.5" D x 53" H



FEATURES

- Steel and wire rack
- Use in displays or on cooler doors
- Heavy duty suction cups keep rack firmly secured
- Safety hook included



BUILD CAPACITY

- 6 - 24/25oz. cans only

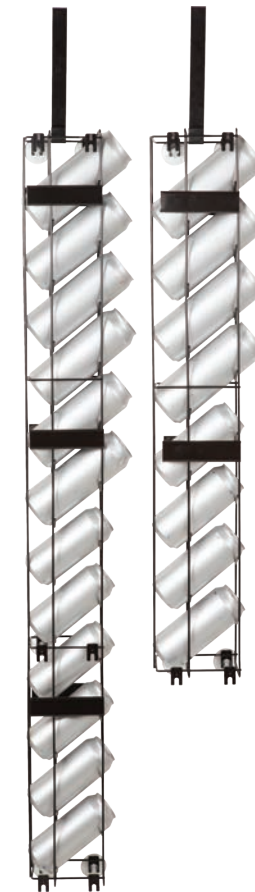

SIDE LOADER



FEATURES

- Made from #9 B.B. 1008 wire
- Use in displays or on cooler doors
- 4-6 mushroom suction cups on per rack



DIMENSIONS

8 RACK
5.5" W x 4" D
x 35.5" H

12 RACK
5.5" W x 4" D
x 51.5" H



BUILD CAPACITY

- | | |
|---------------------|----------------------|
| • 8 - 12oz. bottles | • 12 - 12oz. bottles |
| • 8 - 16oz. cans | • 12 - 16oz. cans |
| • 8 - 20oz. bottles | • 12 - 20oz. bottles |
| • 8 - 24/25oz. cans | • 12 - 24/25oz. cans |



||

BREEZERS
REFRIGERATED MERCHANDISERS



BREEZER UR-1



DIMENSIONS

29.5" W x 27.375" D x 78.75" H



FEATURES

- Cyclopentane insulation
- Heavy duty wire shelves
- LED perimeter lighting
- Locking high efficiency glass door
- Electronic temperature controller
- Eco-friendly R134a refrigerant



BUILD CAPACITY

- 315 - 12oz. cans
- 315 - 16oz. cans
- 240 - 20oz. bottles
- 240 - 24/25oz. cans



BREEZER UR-2



DIMENSIONS

54.125" W x 29.625" D x 78.375" H



FEATURES

- Cyclopentane insulation
- Heavy duty wire shelves
- LED perimeter lighting
- Locking high efficiency glass door
- Electronic temperature controller
- Eco-friendly R134a refrigerant



BUILD CAPACITY

- 630 - 12oz. cans
- 630 - 16oz. cans
- 480 - 20oz. bottles
- 480 - 24/25oz. cans

NEW

HAND SANITIZERS

IRP's Sanitizer Series offers three options to suite a customer's needs, functionality, and price-point. Whether the customer is looking for a budget-friendly small footprint option or the ability to dispense gallon size jugs, IRP has a solution for every business. All units in the Sanitizer Series are Made in the USA and readily available for shipment.



DURABILITY



COST EFFECTIVE
CONSTRUCTION



MADE IN
THE USA



SLIMLINE SANITIZER STAND



DIMENSIONS

17" W x 14" D x 45" H



FEATURES

- All materials suitable for outdoor use
- ACM/SS/High Density Polyethylene Construction, will not rust or rot
- Easily assembled
- Mounting plate allows for the use of most automated dispensers
- Optional 700mL automatic dispenser



ROTOTOUGH SANITIZER STAND



DIMENSIONS

15.5" W x 16.25" D x 47.5" H



FEATURES

- Large mounting plate allows for the use of most automated dispensers.
- Body and mounting plate are designed with ADA compliance in mind.
- Tilt-casters and built in handle allow easy transportation.
- Base can be filled with water or sand for added stability.



FOOT PUMP HAND SANITIZER



DIMENSIONS

20" W x 15" D x 42.375" H



FEATURES

- All materials suitable for outdoor use
- ACM/SS/High Density Polyethylene Construction
- Built-in anti-theft using tubular lock
- Integrated pump stroke adjustment to control volume of sanitizer dispensed
- Adjustable to fit various 1gal bottles & pump styles



GRIZZLY
COOLERS & DRINKWARE



Grizzly®

The Grizzly name stands for durability, longevity, and reliability. At Grizzly, we pride ourselves on performance and strive to create the best coolers in the market. Our rotationally molded coolers are made by the enthusiast providing optimum performance for all adventures.

We have proudly envisioned, engineered, tested, and perfected our coolers in the U.S.A., our oath to you is **FOR A LIFETIME**. We stand by our products with a Lifetime Warranty and a Bear-Proof certification from the Interagency Grizzly Bear Committee.



GRIZZLY 15

15QT CAPACITY
14.375" W x 18.75" D x 11.375" H



GRIZZLY 20

20QT CAPACITY
14.25" W x 20.25" D x 14.5" H



GRIZZLY 40

40QT CAPACITY
15.375" W x 25.5" D x 16" H



GRIZZLY 60

60QT CAPACITY
17.25" W x 30.375" D x 17.375" H



GRIZZLY 75

75QT CAPACITY
17.875" W x 33.125" D x 17.75" H



GRIZZLY 100

100QT CAPACITY
20.125" W x 37" D x 18" H



GRIZZLY 165

165QT CAPACITY
22.75" W x 47.75" D x 19.625" H



GRIZZLY 400

400QT CAPACITY
31.875" W x 54.5" D x 31" H

HARD COOLER CUSTOMIZATION

ADHESIVE



- Printed w/overlaminated adhesive
- Full color/full coverage
- Most durable type of printed graphic
- Minimum orders of one (1)
- Printed in-house up to 50 qty
- Lid & body capabilities (exclude G400)
- Spot color backgrounds using a printed color - not 100% match
- Two (2) week lead time

MOLD-ON GRAPHIC



- Spot color ONLY (1-4 color logos)
- Price increases by number of colors
- Front or lid graphics available
- 10" coverage regardless of cooler size
- Durable
- Flamed on post rotomolding process - graphic becomes part of the cooler
- Minimums apply
- Longer lead times of 6-8 weeks

MOLD-IN GRAPHIC



- Spot color
- Lid only
- Durable
- Graphic done during rotomold process - graphic becomes part of the cooler
- Lead times of 6-8 weeks for graphics PLUS production lead time on coolers

DEBOSSSED LID



- Lid only
- 90 day+ lead time
- Available on models G15, G20, G40, G60, G75
- Permanent lid branding
- Set-up fee required

DIRECT PRINT



- Directly printed on lid
- Full color - either CMYK or spot graphics (PMS Colors)
- NOT full coverage
- No width limits, can't cover Grizzly logo
- Lid only
- UV cured ink with varnish protected
- Least durable type of printed graphic
- Minimum orders of one (1)
- Two (2) week lead time

COLOR OPTIONS

- Compound color - 10,000lbs.
- Dry mix color - 3 weeks lead time + 1,000lbs. minimum
- Mix and match standard lids & bodies - 25 minimum
- Standard colors include:

G15, G20, G40, G60

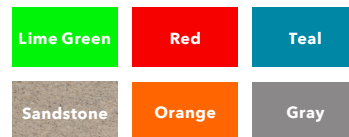

ALL SIZES



GRAPHIC AREAS

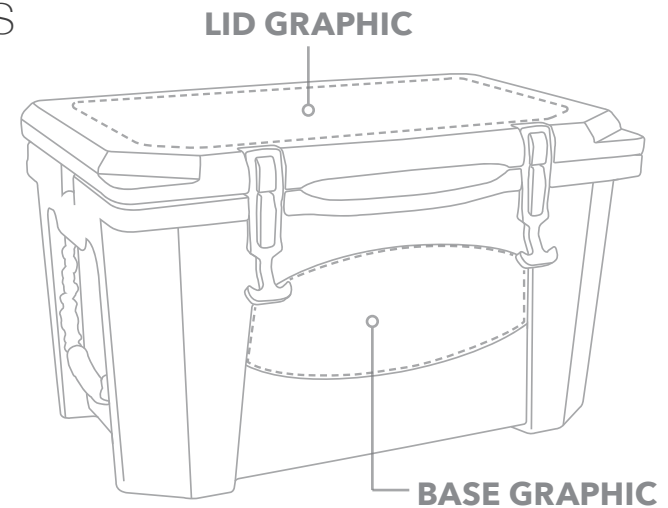



GRIZZLY DRIFTER 12+



DIMENSIONS

12" D x 13.5" H x 9" W



FEATURES

- Waterproof ballistic polyester shell
- Easy opening zippers
- 100% waterproof TPU liner
- Compression molded lid and base
- Padded shoulder strap
- EVA foaminsulated lid and base
- Neoprene gear band



BUILD CAPACITY

- 12 quartz



GRIZZLY DRIFTER 20



DIMENSIONS

12" D 13.75" H x 15.5" W



FEATURES

- Waterproof ballistic polyester shell
- Easy opening zippers
- 100% waterproof TPU liner
- Compression molded lid and base
- Padded shoulder strap
- EVA foaminsulated lid and base
- Neoprene gear band



BUILD CAPACITY

- 20 quartz

SOFT COOLER CUSTOMIZATION

HEAT TRANSFER



- CMYK - Full color
- Front - 5" Wide x 3.5" Tall
- Side Pocket - 3" Wide x 5" Tall
- Back - 5" Wide x 4.5" Tall
- 2 week lead time

SILICONE PRINT



- Spot color
- Front - 5" Wide x 3.5" Tall
- Side Pocket - 3" Wide x 5" Tall
- Back - 5" Wide x 4.5" Tall
- 2 week lead time

FULL CUSTOM



- Pantone specific color matching
- Minimum orders of 2500 for Drifter12+, 1500 for Drifter 20
- 120 days lead time till approval date

DYE SUB PRINTED



- CMYK - Full color
- Front only
- 6 week lead time

GRAPHIC AREAS

FRONT

5" Wide x 3.5" Tall

SIDE POCKET

3" Wide x 5" Tall

BACK

5" Wide x 4.5" Tall

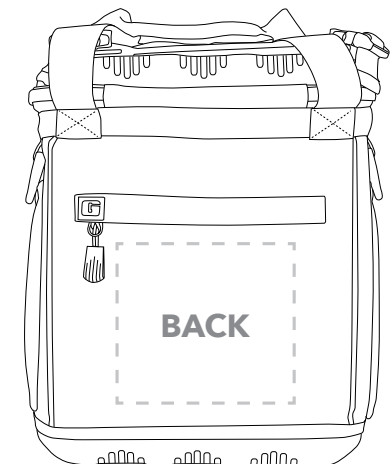
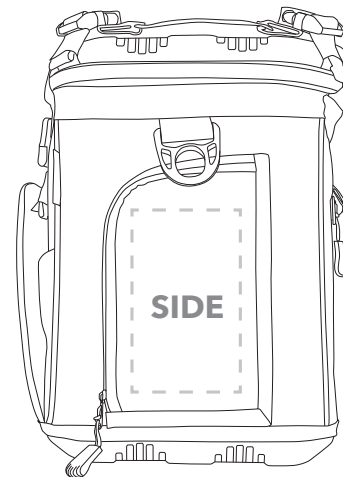
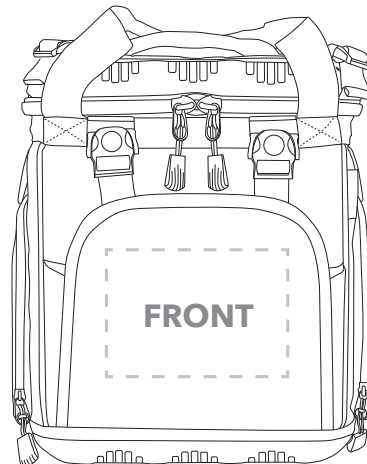



*Blue Moon Light Sky
- Grizzly Slim Can



GRIZZLY CAMP CUP



GRIZZLY CAN COOLER



GRIZZLY SLIM CAN



GRIZZLY POUNDER



GRIZZLY GRIP - 20OZ



GRIZZLY GRIP - 32OZ

DRINKWARE CUSTOMIZATION

ENGRAVING



- Single color
- Powder Coated only
- Best durability
- Minimum of 12
- No set up fee
- Done in-house

PAD PRINT



- Spot color only
- 1-2 color logos done in-house
- Up to 5 colors outsourced
- Minimum of 50
- Set up fee required
- Lead time varies

DIGITAL PRINTING



- Full color
- Largest graphic area
- Minimum of 24
- Set up fee required
- Done in-house

COLOR OPTIONS

GRIP - 20oz.



GRIP - 32oz.



CAMP CUP



POUNDER



CAN COOLER



SLIM CAN COOLER



AVAILABLE IMAGE AREA

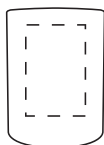

CAMP CUP

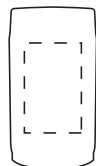

CAN COOLER

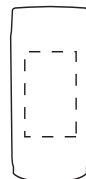

SLIM CAN COOLER

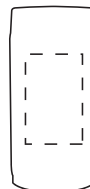

POUNDER



GRIP - 20OZ



GRIP - 32OZ



Miller
Lite

CELEBRATE RESPONSIBLY™



Miller
Lite

Miller
Lite



**IOWA
ROTOCAST
PLASTICS, INC.**
PLASTIC. FABRICATION. WIRE.

Miller
Lite

Check out our full line of services and more great products at
IRPINC.COM or follow us online at    [IRPINC](https://www.IRPINC.COM)